



La SM3000 es una brocheta automática para pequeñas y medianas empresas, capaz de producir una gran variedad de brochetas.



INFORMACION GENERAL

Dimensiones

Ancho: 900 mm
 Largo: 1.525 mm
 Alto: 1.470 mm
 Peso: 300 Kg

Especificaciones mecánicas

Potencia total: 1,5 kw
 Voltaje: 240 V 2P + T, 50/60 Hz
 Consumo de aire comprimido: 100 Nlitr/min
 Presión de aire comprimido: 0,81 Mpa (8 bar)

Especificaciones ambientales

Ruido inferior a 70 dB (A)
 Humedad ambiente recomendada inferior al 70%
 Temperatura de almacenamiento y uso de +1°C a +25°C



FORMATOS SOPORTADOS

La tabla indica los distintos formatos que el SM3000 es capaz de producir. Para procesar los distintos formatos, es necesario montar en la máquina el kit correspondiente al formato elegido.



X (formato)	Largo (mm)	B (mm)	Un (mm)	piezas/cubo	gramo. cada	cubos/hora	Kg. por hora
14x14	90-250	10-40	máximo 110	225	máximo 22	12	máximo 50
15x15	90-250	10-40	máximo 110	196	máximo 25	12	máximo 55
16x16	90-250	10-40	máximo 110	169	máximo 32	13	máximo 70
19x19	90-250	0-40	máximo 160	121	máximo 70	14	máximo 76
21x21	90-250	0-40	máximo 160	100	máximo 75	15	máximo 110
24x24	90-250	0-40	máximo 160	81	máximo 90	15	máximo 98
27x27	90-250	0-40	máximo 160	64	máximo 115	dieciséis	máximo 115
30x30	90-250	0-40	máximo 160	49	máximo 150	20	máximo 137
15x30	2x90-250	10-40	máximo 110	91	máximo 50	18	máximo 82
21x42	2x90-250	0-40	máximo 160	45	máximo 150	15	máximo 110



DESCRIPCIÓN GENERAL

Algunas fotos de los principales pasos del procesamiento.

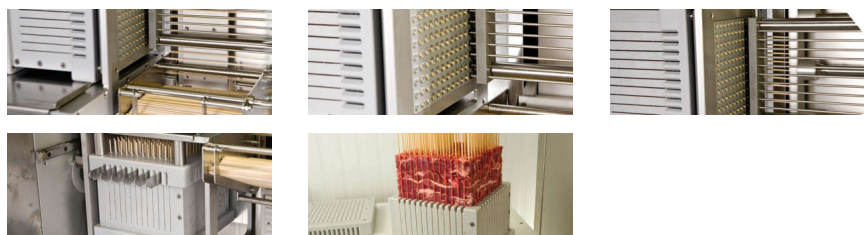

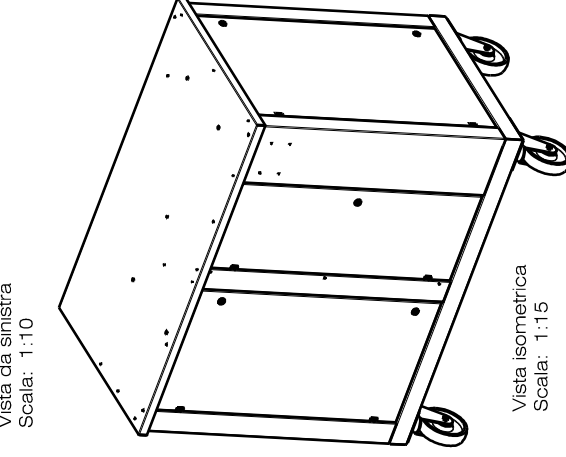
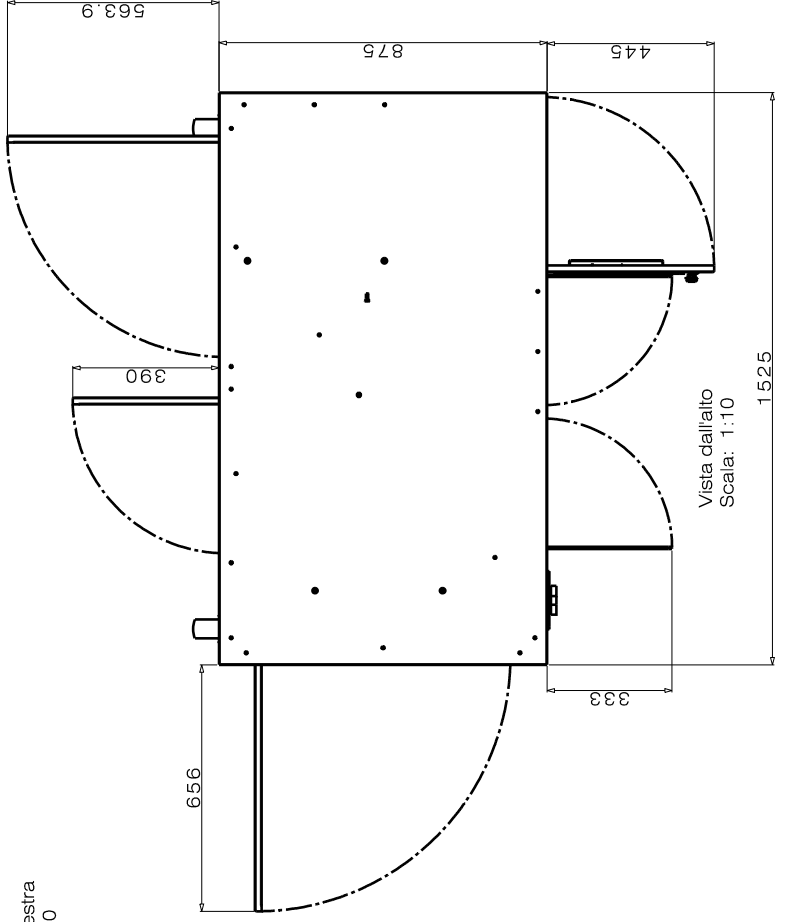
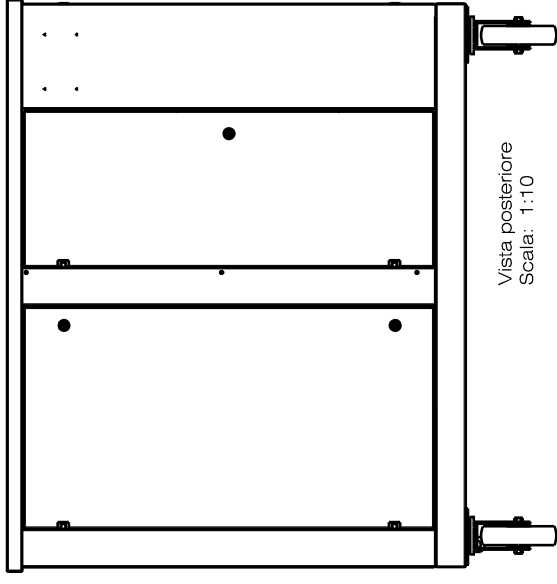
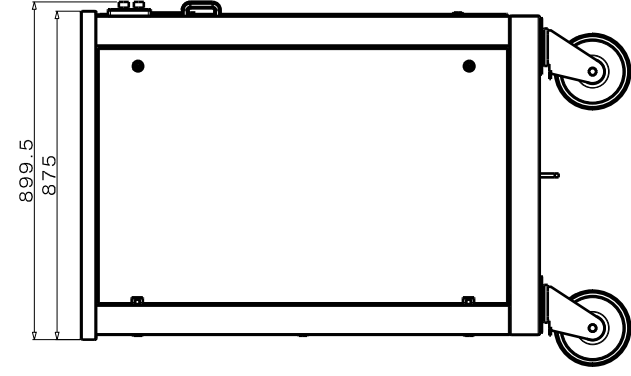
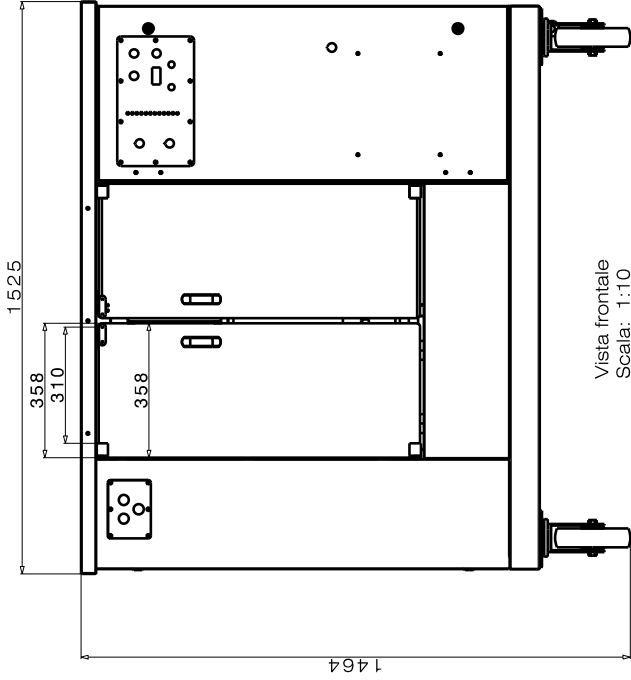

<p>FOOD PROCESSING EQUIPMENT V.A. di Food Processing Equipment Via S. Felice 12, 20122 Milano, Italia Tel. 02 57491111 Fax 02 57491122 www.vnfood.com e-mail vn@vnfood.com</p>	<p>ELIMINARE LE BAVE ROMPERE GLI SPIGOLI VIVI TOLLERANZA GENERALE ±0.1 SPIGOLI NON QUOTATI 0.5x45</p>		<p>Descrizione SM3000</p>		<p>Disegnato Data: 30/10/08</p>										
	<p>Assieme SM3000</p>		<p>N° Assieme 1201</p>		<p>REVISIONI</p> <table border="1"> <tr> <td>A</td> <td>7/11/08</td> </tr> <tr> <td>B</td> <td>12/01/09</td> </tr> <tr> <td>C</td> <td>21/01/09</td> </tr> <tr> <td>D</td> <td>XXX</td> </tr> <tr> <td>E</td> <td>XXX</td> </tr> </table>		A	7/11/08	B	12/01/09	C	21/01/09	D	XXX	E
A	7/11/08														
B	12/01/09														
C	21/01/09														
D	XXX														
E	XXX														
<p>Materiale: XXX</p>	<p>Commessa N° disegno 1201</p>	<p>Gruppo Fino a 300</p>	<p>Prezzo (kg) XXX</p>	<p>Scala 1:1</p>	<p>Treatments XXX</p>	<p>Trattamenti A2</p>									
<p>N° pezzi per macchina XXX</p>	<p>Grado di precisione 10</p>	<p>Prezzi Fino a 300</p>	<p>Prezzi Fino a 300</p>	<p>Prezzi Fino a 300</p>	<p>Prezzi Fino a 300</p>	<p>Prezzi Fino a 300</p>									

A meno di 100g o in seguito la proprietà
passerà automaticamente al fornitore di comunicazione a terzi
senza essere autorizzata